

# OxyGuard Probes - today

August 2007

Since the start in 1987 OxyGuard have produced many Oxygen Probes.

OxyGuard have introduced improvements where possible to ensure that the OxyGuard probe is always the best on the market.

Today three main types of mechanical design can be found in use.

There are several types of chemistry.

Several membrane types.

This document will help you find out what is what, and is valid for all but a few special types. Users of these know that they have special probes.

## PROBES MADE TODAY ARE TYPE 3 PROBES:

These probes have:

3 dots on the top.

NO vent hole.

NO O-ring between the cap and the upper part.

Type 3 anode and electrolyte.

### Type 3 chemistry.

Type 3 anode (D10AN3).

Type 3 electrolyte (D10E31L).

Check - brown-black deposits in probe and possibly on anode.

For ALL uses.

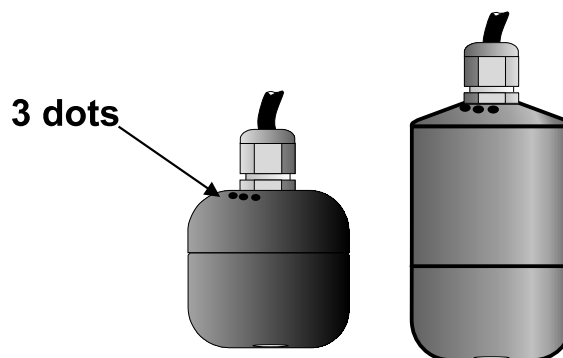

NB. If you find a type 3 probe with red collar on the cable and NO brown-black deposits inside it please replace the anode with a type 3 anode and fill it with type 3 electrolyte.

**TYPE 3 PROBES MUST NOT BE OPENED UNLESS THE MEMBRANE IS DAMAGED OR, AFTER LONG USE, THE PROBE OUTPUT IS TOO LOW, I.E. IF CALIBRATION UP TO THE CORRECT VALUE IS IMPOSSIBLE.**

YOU CAN IDENTIFY A TYPE 3 PROBE BY THE THREE DOTS AND THE DARK BROWN OR BLACK DEPOSITS INSIDE THE PROBE.

For % sat and volume measurements use D10MSV membranes. These membranes have blue backing paper.

For mg/l (ppm) measurements use D10MM membranes. These membranes have yellow backing paper.

For Commander probes use D10MC membranes; for Model 840 and 810 probes use D10M840 membranes. These are special % membranes, and have grey backing paper.

# OxyGuard Probes - before January 2003

## PROBES MADE BEFORE JUNE 2000

These probes have:

**A vent hole**

**2 grooves in the thread.**

**A large THICK O-ring (D10LOR1) that must be placed in the groove in the upper part.**

These can have the following chemistry:

### Type 1 chemistry.

Type 1 anode (D10AN1)

Type 1 electrolyte (D10E11L)

*Check - white deposits on anode and possibly in probe*

Use for dissolved oxygen and oxygen in gas, *but NOT pure oxygen.*

### Type 0 chemistry.

Type 1 anode (D10AN1)

Type 0 electrolyte (D10E01L)

*Check - white deposits on anode and possibly in probe.*

Use for pure oxygen.

### Type 2 chemistry.

Type 2 anode (D10AN2)

Type 2 electrolyte (D10E21L)

*Type 2 probes were delivered with a red collar on the cable.*

Use for low levels of dissolved oxygen or low levels of oxygen in gas.

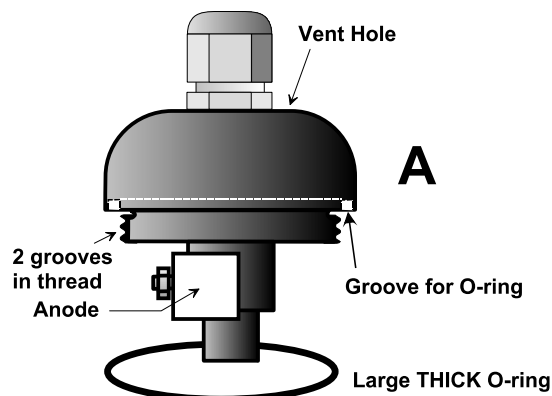

For % sat and volume measurements use D10MSV membranes. These membranes have blue backing paper.

For mg/l (ppm) measurements use D10MM membranes. These membranes have yellow backing paper.

## PROBES MADE FROM JUNE 2000 TO NOVEMBER 2002

These probes have:

**A vent hole.**

**4 grooves in the thread.**

They can have type 0, 1 or 2 chemistry - see above.

They use D10MSV or D10MM membranes.

This type of probe must be tightened very hard indeed.

A large, THIN O-ring, 45 x 1.6 mm, (D10LOR2) can be used at the top of the thread if there is a recess at the top of the thread.

If there is an insert in the vent hole it should be removed.  
NB The insert is in TWO parts - remove both.

**Contact OxyGuard if problems are experienced.**

