

Oxygen Measurement

with

OxyGuard

CONTENTS

1) Some basics	2
Some Definitions.....	3
Oxygen Probes	4
Fish Farming - Aquaculture	5
Waste Water Treatment	7
Safety Monitoring	7
Foods and Beverages	7
Environmental monitoring	7
Hand Held Oxygen Meters	7
2) Oxygen - Dissolved oxygen - what are we measuring?	8
Probe Types.....	8
3) Calibration	9
DO Probe Calibration.....	9
% Volume Calibration	9
Automatic Calibration.....	10
4) Maintenance.....	10
DO Probe membrane replacement and renovation	10

To start with - some basic information - mostly for those new to the subject.

1) Some basics

Oxygen, O₂, is the most important building block of very nearly all life here on Earth. The energy we, together with other life forms, use to live and grow comes basically from the chemical combination of oxygen with carbon and hydrogen. This forms carbon dioxide and water, that plants, with the help of energy from sunlight, convert back into food for us and all other manner of beings. Only some recently discovered deep-sea creatures do not use this mechanism.

Air consists of 20.9% oxygen. Despite the vast amounts of fossil fuel that are now being burnt this figure remains, as yet, quite constant. Air-breathing beings have no trouble obtaining the oxygen they need - there is almost 1.5 gram of oxygen in every 5 litres of air, and air mixes and moves around easily. For aquatic life the situation is different - you need 100 litres of cold water to get 1 gram of oxygen. And even more water is needed as the water gets warmer - boiling water contains no dissolved gas. In oceans and lakes it can take some time before "used" water is "refreshed", and areas, or rather volumes, of oxygen-depleted water can move around for long periods of time harming plants, molluscs and other slow-moving aquatic beings. Environmental monitoring of dissolved oxygen and other parameters shows where we should be careful not to place further stress on nature. Modern man uses aquatic life forms - he raises fish for food, uses bacteria to break down waste water. Both are processes where oxygen is measured and controlled to ensure progress as desired.

In some other situations oxygen is unwanted. In the water/steam circuit of a power plant it causes corrosion. In beverages it can change the taste. In a flammable gas it can cause an explosion. In food packages it can speed deterioration. These are instances where very low levels of oxygen need to be measured.

Another important use of oxygen measuring equipment is in the environment. The human population explosion entails a degree of pollution that seriously endangers natural life forms. The measurement of oxygen levels gives a good indication of at least the basic level of pollution.

Some Definitions

- Oxygen probe:** A device that senses the amount of oxygen present.
- Oxygen meter:** A device that incorporates an oxygen probe and a display to show the amount of oxygen.
- Oxygen monitor:** An oxygen meter that incorporates some sort of surveillance or alarm device.
- Oxygen controller:** An oxygen meter with an output that is used to keep the oxygen content at or above a pre-set level.
- Oxygen alarm unit:** An oxygen meter with one or more outputs that indicate when the oxygen level is too low or too high.
- % saturation:** (% sat) For dissolved oxygen, the ratio between the actual oxygen content and that of water that is saturated with air. Note that 100% saturated warm water contains much less oxygen than 100% saturated cold water.
- % volume:** The volumetric percentage of oxygen present in a gas. (Air = 20.9%, pure oxygen = 100%)
- mg/l:** Dissolved oxygen content in milligram oxygen per litre . 100% sat water at 20°C contains 9.1 mg/l.
- ppm:** Dissolved oxygen content in parts per million by weight. Essentially the same as mg/l, since 1 litre of water (depending on temperature) weighs 1000 gram.
- ppb:** Parts per billion dissolved oxygen (microgram per litre).
The DO of steam turbine water and some beverages is usually in the 5-50 ppb range.

Oxygen Probes

"Once upon a time" oxygen content could only be measured by chemical means. Today the easiest and most accurate way of measuring oxygen is to use an oxygen meter, and most oxygen meters, especially dissolved oxygen meters, have membrane covered polarographic sensors that generate an electrical current when they measure oxygen.

Until the OxyGuard probe was introduced Clark cells were the predominant type of oxygen probe. To make a Clark cell work you have to apply a voltage to it, and the current through it then is proportional to the oxygen it senses. Clark cells "run down" - electrolyte is consumed and its response time increases with age due to changes inside the probe. The applied voltage makes zero and span calibration necessary, and the cell has to warm up after the voltage has been switched on.

Today the OxyGuard probe (and copies of it) is the most widespread since it has some inherent advantages over Clark cells. It is worthwhile to note that if you come across a spherical or cylindrical oxygen probe made of black plastic about 6 cm in diameter it is most likely either an OxyGuard probe or a copy. You should also note that there is a widespread belief that **all** oxygen probes "run down" and change their sensitivity like the Clark cell - this is **not** so for the OxyGuard probe.

The OxyGuard probe is of the Mackereth cell type. The main advantages of this type of cell are:

- 1) you do not have to apply a potential to it to make it work - it generates its own electricity;
- 2) The OxyGuard type of oxygen sensor is always ready for use - it does not need to "warm up";
- 3) The OxyGuard cell has a true zero, it only needs a span calibration;
- 4) This type of sensor reacts quickly to changes in oxygen level;
- 5) The OxyGuard type cell does not decay or lose sensitivity with age - it maintains its efficiency - so **YOU DO NOT HAVE TO PERFORM MAINTENANCE ON A REGULAR BASIS.**
It is necessary to keep the membrane of any membrane covered oxygen sensor reasonably clean since deposits (bacteria, fat etc.) on the membrane will act as a barrier to the oxygen the cell is trying to measure. The OxyGuard probe is significantly less sensitive to such deposits than other probes
- 6) Another advantage of the OxyGuard probe is that it is temperature compensated. The sensitivity of oxygen probes can vary with temperature, but OxyGuard probes have built-in temperature compensation so that you always obtain the correct measurement.

The use of oxygen meters, oxygen monitors and oxygen controllers - both for dissolved oxygen and gaseous oxygen - has increased dramatically during the last 15 years - i.e. since the introduction of the OxyGuard oxygen probe and oxygen monitoring equipment. OxyGuard International A/S was founded specially to meet the growing need for dissolved oxygen and gaseous oxygen meters, monitors and controllers, and since then the need for more precise knowledge of and control of oxygen content has gone hand in hand with the emergence of new types of oxygen meters, oxygen monitors and oxygen controllers.

The following pages show where oxygen probes, oxygen meters, oxygen control and alarm equipment are most often used.

Fish Farming - Aquaculture

Fish farming is carried out all over the world, and has been for thousands of years. Today the ancient principles of raising fish in natural or man-made ponds without the use of any technology can still be found, in strong contrast to the modern intensive methods used in areas where fish farming has become the Aquaculture Industry. OxyGuard has helped this change by providing the water quality monitoring and control equipment without which it would not have been possible.

The technology used in raising fish today ranges therefore from occasional DO checks in natural ponds using a hand-held meter, to the automatic measurement and control of DO, temperature, pH and other parameters in water that is re-circulated and used many times.

An additional type of facility is a sea-cage on growth facility. Previously not much was done in the way of monitoring water quality in such facilities, but today's narrow profit margins together with the very large value of the fish in such a sea cage system means that advanced monitoring and even oxygenation is now being introduced.

Simple farms - e.g. a Trout Farm

Here water is not recirculated, but flows through the ponds or raceways where the fish are raised. By injecting oxygen into the inlet water more fish - perhaps up to three times more - can be raised in the same quantity of water. It can also be necessary to inject oxygen into the outlet water to meet environmental demands. Further control of dissolved oxygen can be effected using diffusers in individual ponds or raceways. Similarly, temperature and pH monitoring and control can be added.

Farms with re-circulating water

Here the water is used many times. A comparatively small amount of fresh water is continually added. Water returning from the tanks, raceways or ponds is filtered biologically or mechanically, purified using ozone or ultra-violet light, pH adjusted and oxygenated before being sent on to the tanks, raceways or ponds. Other parameters, for example carbon dioxide or ammonium, are checked and action taken as needed.

The oxygen that is thus in the water is regarded as the basic oxygen supply, additional oxygen is added using diffusers in individual tanks etc. This is effected using DO measurements in each tank, raceway or pond.

An alternative to using diffusers in individual tanks is to use a supply of super-oxygenated water at high pressure, and regulate the addition of this individually. Pipe-mount DO probes, flange mount DO probes or flow cell DO probes can be used in such high pressure oxygenation systems.

Hatchery and growth tanks

These usually use recirculated water. Water level as well as dissolved oxygen should be measured in each tank - the water supply to one tank could be cut off. Oxygen level alarms are set on the DO measurements. Oxygen injection to each tank is controlled using a control loop with the DO level as the process variable so that differences in the bio-mass and feed demand can be taken into account. Often only the "last" 10 or 20% of the oxygen need is provided through this control loop - the basic need is provided by the oxygenation system of the feed water. Such a system, especially when controlled with the accuracy and flexibility offered by a Commander system, provides optimum growth in a modern fish farm.

Sea cages

DO measurement is very important here because feed uptake and DO levels are interconnected. Feeding after fish have experienced low DO levels can actually be harmful. Feed can be dosed according to the measured DO, and alarm can be given to warn that the cage should be moved or aeration started if extremely low DO levels should occur.

Some sea cage systems are fitted with oxygenation systems. Dissolved oxygen levels are measured at several depths and positions. If, for example due to warm weather or tidal flow, the DO level falls oxygenation can be turned on. Here again, the features of the Commander system can be used to advantage.

Transport tanks

DO measurement should also be performed during the transport of juvenile fish (e.g. smolt) to tanks or cages for on-growing as well as during the transport of mature fish to the processing plant. The OxyGuard Convoy system is specially designed for this purpose. Data logging provides proof that the fish have not suffered during transport and guarantees that the quality of the product is suitable for further processing. Land transport is carried out in lorries fitted with a number of tanks, sea transport by well boats.

Shrimp Farms

Shrimp are raised in very large, shallow ponds. Often paddle wheel aerators are used to create circulation and aerate the water. If, as often happens, the DO level in the water is above 100% saturation due to photosynthesis, the use of paddle wheels will actually lower the DO level in the water, since aeration - thorough aeration - will bring the DO level to 100% no matter whether the start value is below or above 100%.

OxyGuard have designed the Model 810 for use in such farms. This small unit has an analogue output and a limit switch contact output. It can be used to turn paddle wheel or other aerators on if the DO level falls below a set value measured in % saturation.

It is usually necessary to ensure circulation in the pond - this can be done using effective propellers or impellers. Temperature measurements can be used to switch these devices on or off.

Pure oxygen measurement

Two of the many advantages of using pure oxygen are that 1) it is possible to super-saturate the water with oxygen and 2) you save pump energy since pumping air means pumping 79% nitrogen and "only" 20.9% oxygen. Pure oxygen is obtained either from liquid oxygen in bulk or from local oxygen generators. Pure oxygen meters (oxygen purity meters), controllers and alarm units are used as needed.

Waste Water Treatment

Sludge tank DO measurement and control

Here single-channel dissolved oxygen meters, 2-wire dissolved oxygen probes and dissolved oxygen controllers are met. The dissolved oxygen level is kept at approximately 2 mg/l. Pure oxygen can be used, so oxygen purity meters, controllers and alarm units can be used.

Effluent monitoring and oxygen level control

Effluent is often monitored using 2-wire dissolved oxygen probes or single-channel dissolved oxygen meters. Aeration or oxygenation is controlled accordingly. Pure oxygen can be injected to give an extra oxygen content, i.e. a super-saturated DO level, to "burn off" organic pollutants that consume oxygen when they break down.

pH measurement and control, flow measurement, suspended solids measurement, sludge blanket detection, conductivity measurement, nitrate measurement and phosphate measurement are also all used to enable the efficient and effective cleaning of waste water.

Safety Monitoring

Both oxygen detection in flammable gas and oxygen monitoring in ambient air are examples of this. Special versions of the OxyGuard probe are approved for use in potentially dangerous atmospheres, i.e. in EX classified areas.

Foods and Beverages

OxyGuard also make equipment to check the oxygen content of food packaging gas as well as the PPB DO levels in drinks such as beer and the elevated DO levels in oxygenated drinks. The latter need probes that can be cleaned at high temperatures.

Environmental monitoring

Dissolved oxygen data loggers can be left to record DO fluctuations in lakes, rivers etc. Deep sea oxygen probes are used in oceans and deep lakes or fjords. Profiling probes that are either raised and lowered in the water or towed through the water at different depths are used to map the dissolved oxygen content of lakes and fishing waters.

Hand Held Oxygen Meters

These are found in numerous shapes and sizes. A hand held or pocket size dissolved oxygen meter should meet certain criteria. It should be a waterproof DO meter, show DO in both % sat and mg/l (ppm), have automatic temperature compensation and should always be ready to measure. It should be as near as possible to a maintenance-free DO meter. More advanced types should have automatic calibration and pressure compensation as well as salinity compensation and data logging or data recording functions. All the meters of the OxyGuard "Handy" range are a good examples of such meters.

2) Oxygen - Dissolved oxygen - what are we measuring?

In actual fact all oxygen probes like the OxyGuard probe measure the partial pressure of oxygen present at the membrane. The chemistry of the probe consumes all oxygen inside it. There is therefore a partial pressure difference across the membrane that only depends on the partial pressure outside the membrane - there is no oxygen on the inner side of the membrane. Oxygen thus diffuses through the membrane at a rate proportional to the oxygen partial pressure outside the membrane.

Each oxygen molecule that enters the probe transfers an electrical charge between the cathode and anode, creating an electrical current proportional to the oxygen partial pressure outside the probe. This current, either directly or transformed to a voltage, forms the output of the probe. To find out what this output represents you need to calibrate the probe first, by placing the probe somewhere with a known oxygen partial pressure - for example, in the air.

If you are measuring oxygen in gas form you will measure in % oxygen by volume, using the 20.9% present in the air as the calibration value. If you measure at a different pressure to that at which you calibrated the probe you must make a correction for the changed pressure. For example, the output of a probe in air at 2 bar pressure will be twice that at 1 bar pressure.

If you measure dissolved oxygen in % saturation the oxygen partial pressure of the air per definition represents 100% saturation. Changes in air pressure will affect the partial pressure that corresponds to 100% saturation, so calibration at the actual pressure is necessary to obtain the greatest accuracy.

If you measure dissolved oxygen in mg/l (ppm) then temperature also must be taken into consideration. The amount of oxygen that can be dissolved in water varies with temperature in a non-linear fashion, so tables must be used when calibrating. In some instruments these tables are incorporated into the microcomputer inside the instrument. For example, at 20°C and a barometric pressure of 760 mm Hg water that is saturated with air contains 9.1 mg/l oxygen. If you therefore calibrate an oxygen probe in air at 20°C and 760 mm Hg pressure you must adjust your equipment to show 9.1 mg/l. Calibration tables are included at the back of this document.

OxyGuard probes are fully internally temperature compensated. For example, if you have a mg/l probe you just have to calibrate it correctly, then it will measure correctly at all temperatures between 0 and 40°C.

Probe Types

- For Aquaculture and similar dissolved oxygen uses, waste water treatment, oxygen in air/gas and for use on pure oxygen the Type 3 probe is used.**
- Model 420 is a probe with built-in 4-20mA transmitter.**
- The Model 810 is designed for aerator control in ponds.**
- For waste water use the Model 840.**
- For deep sea measurements use the OxyGuard Ocean probe.**
- For profile measurements use the OxyGuard Profile probe (you can both raise and lower as well as tow the Profile through the water.)**

Please contact OxyGuard if you want to measure super-saturated water.

Please contact OxyGuard if substantial concentrations of either CO₂ or H₂S are found in the water.

3) Calibration

DO Probe Calibration

Calibration is carried out by placing the probe in air or air saturated water, waiting for temperature equalization then adjusting the transmitter so that the display shows the calibration value. If you are measuring % saturation the calibration value is always 100%. If you are measuring mg/l (ppm) temperature, the barometric pressure and the water salinity all affect the calibration value.

The probe must have the same temperature as the water or air it is calibrated in and must be allowed to attain this temperature before being calibrated. Any robust long-life probe such as the **OxyGuard** can take up to an hour to respond to a 10 degree temperature change in air, which only takes 10 minutes in water. This must be taken into consideration!

An easy way to calibrate is to use the **OxyGuard EasyCal** calibrator. Just place the probe in the **EasyCal** holder, return it to the water and read the calibration value from the **EasyCal** display! No need to refer to tables, and it only takes a few minutes.

If you do not use the EasyCal take the probe up from the water, wipe the membrane dry, and hang the probe in free air, away from direct sunlight. If necessary wrap aluminium foil around it. You must now wait for temperature equalization. When the signal is steady you can adjust the equipment to show the correct calibration value.

Calibration Value for Systems Measuring % Saturation

The calibration value for systems measuring % sat is always 100. For these systems, and only for these systems, temperature, barometric pressure and salinity have no influence.

Calibration Value for Systems Measuring mg/l

For these measurements adjustment is made to show the appropriate value from the calibration tables. Temperature, pressure and salinity affect the value. If you are using an **OxyGuard EasyCal** the correct value is shown on the **EasyCal** display.

It is essential to correct for temperature - use the air temperature near the probe. At high altitudes, or for greater accuracy, a correction must be made for pressure. The salinity should be corrected for in salt-water measurements. Salinity can be measured with the OxyGuard Refractometer

How often should calibration be performed?

Unfortunately, it is not possible to answer this question. Under ideal conditions (in air) the probe can keep its calibration for many months. In use in water the actual conditions (e.g. the nature of deposit build-up) and the desired accuracy will dictate calibration frequency. It is very important that calibration is performed with care. Give the probe good time to stabilize, check the barometer and decide if correction is necessary. Check the salinity if you measure in salt water.

% Volume Calibration

Systems measuring gaseous oxygen - pure oxygen, the air or gas with low oxygen content, are either calibrated in the air to 20.9 % or in a calibration gas, in which case the oxygen content will be shown on the gas bottle.

Automatic Calibration

The Model 840, Model 810, the Handy Polaris, Handy Delta and the Commander system have automatic calibration. "Put the probe in air and press the button". You should, however, make sure that the probe temperature is the same as or very close to that of the air before you push the button, otherwise calibration will not be successful. The equipment can sense when the temperature - or the oxygen value - is not steady. Commander and the Handy Polaris and Delta also incorporate automatic compensation for barometric pressure changes.

4) Maintenance

In the OxyGuard probe the electrolyte does NOT "wear out" or get used up. The anode is oxidised, but there is enough anode material for very many years of use indeed, even when measuring pure oxygen. Oxide on the anodes of OxyGuard probes does NOT affect the performance of the probe. If desired the anode can easily be replaced. The only factor that affects the working of an OxyGuard probe is a factor that affects all probes with membranes - deposits on the membrane.

OxyGuard oxygen probes do NOT need regular maintenance or service – just keep the membrane reasonably clean

If you can calibrate to the correct value you should not open the probe, even if it has been in use for many years. If the membrane should be damaged membrane replacement will, of course, be necessary, but the procedure, which also renovates the probe, is easy and can be performed on-the-spot by anyone, as described later in this manual. Necessary spares are shipped with the probe.

Deposits develop on all surfaces in any biologically active system, and a deposit that builds up on the membrane of any oxygen probe will change the sensitivity of that probe. OxyGuard probes are designed so that deposits have little influence, but for the greatest accuracy you should keep the probe clean, just as it was when you calibrated it. Deposits should be wiped off the membrane with a cloth or paper. The cleaning frequency will depend on the accuracy desired, how fast deposits build up and on their exact nature.

DO Probe membrane replacement and renovation

The probe's membrane should be wiped clean from time to time. **The probe should not be taken apart unless the membrane is damaged or unless, after long use (some years), you cannot calibrate up to the correct value.**

NB Most probes are now of type 3. Older probes can be type 1 or type 2. These types have different electrolyte and anodes. Make sure that you use the correct electrolyte - and anode if you want to change the anode.

The probe can be fitted with membranes either for mg/l or for % saturation measurement. Probes for systems with automatic calibration use special % membranes. When renovating make sure you use the right membrane.

To replace the membrane and/or renovate the probe proceed as follows:

- 1) Remove the probe, rinse it and unscrew the cap. If it sticks, tap the side of the probe gently with a hammer then try again. Discard the electrolyte, rinse the cap and top part, clean off any brown or black oxide deposits.
- 2) Inspect the anode. If very corroded the anode can be replaced. Check that the nut under the anode is tight before fitting a new anode. Wash the new anode in soapy water before use to remove any protective oil.
- 3) Check the cathode and remove any deposits using the grey plastic abrasive pad supplied with the probe or a little wet or dry emery paper, grade 600. The cathode **MUST NOT BE POLISHED**.
- 4) Rinse and dry the top part.
- 5) You can at this stage perform an easy check on the probe. Dry the probe – especially the cathode and area around it - completely, then observe the display – the probe should have zero output (less than 0.01 mV when measured at the probe). Contact your distributor if this is not the case.
- 6) Fill a new (or renovated) cap to the brim with electrolyte – the excess electrolyte helps remove any air bubbles. Locate the flat machined from the thread. Lower the upper part into the cap and turn the cap half a turn to engage the thread. Tilt the probe 15° so that the flat is uppermost and screw the cap onto the top part. Excess electrolyte and air should dribble out at the flat.

It is important that the probe is filled completely. Shake it close to your ear. If you can hear the electrolyte splashing around inside it open it, re-fill it and try again.

WHEN YOU ARE CERTAIN THAT THE PROBE IS FILLED COMPLETELY TIGHTEN THE CAP **HARD**.

After renovation the probe can be regarded as new. It should be hung up in air to stabilize for at least an hour before calibration. If possible re-calibrate after a day or two.

A new membrane can easily be fitted to the cap - see the drawing. The membrane must be flat - if it wrinkles remove it and try again with a new one. It is important that all parts are clean and dry. Neither membrane nor O-ring can be used more than once, as the membrane stretches to fit the cathode, and will not fit perfectly a second time.

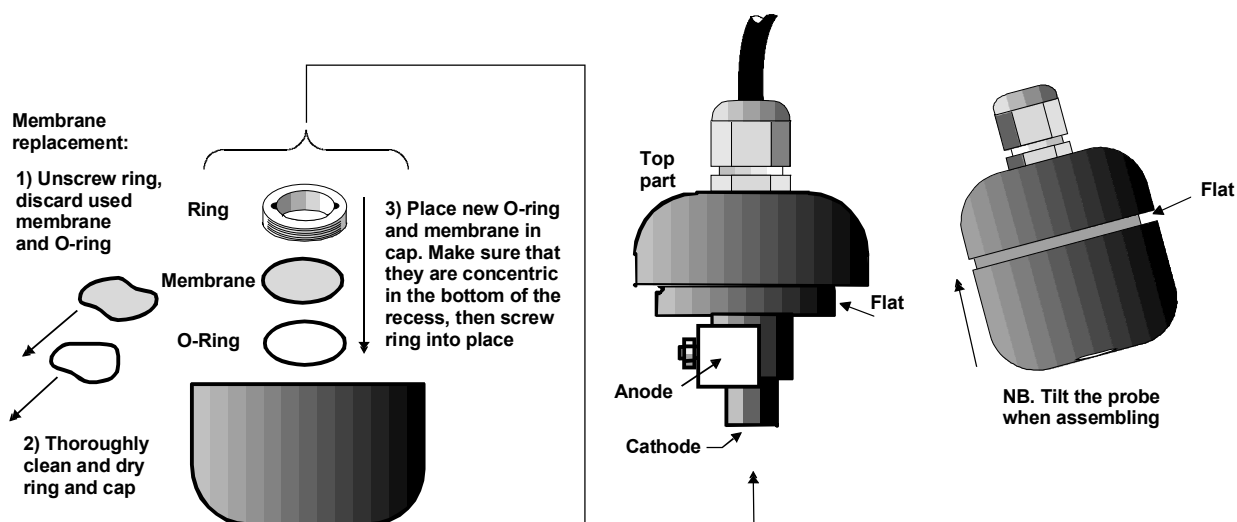

CALIBRATION TABLE - mg/l - FRESH WATER

Barometric Pressure		700	710	720	730	740	750	760	770	780	790	800
mm Hg		700	710	720	730	740	750	760	770	780	790	800
mbar		933	946	960	973	986	1000	1013	1026	1040	1053	1066
Temp	°C											
	°F											
0	32.0	13.4	13.6	13.8	14.0	14.2	14.4	14.6	14.8	15.0	15.2	15.4
1	33.8	13.1	13.3	13.5	13.6	13.8	14.0	14.2	14.4	14.6	14.8	14.9
2	35.6	12.7	12.9	13.1	13.3	13.4	13.6	13.8	14.0	14.2	14.4	14.5
3	37.4	12.4	12.6	12.7	12.9	13.1	13.3	13.4	13.6	13.8	14.0	14.2
4	39.2	12.1	12.2	12.4	12.6	12.7	12.9	13.1	13.3	13.4	13.6	13.8
5	41.0	11.8	11.9	12.1	12.3	12.4	12.6	12.8	12.9	13.1	13.3	13.4
6	42.8	11.5	11.6	11.8	11.9	12.1	12.3	12.4	12.6	12.8	12.9	13.1
7	44.6	11.2	11.3	11.5	11.6	11.8	12.0	12.1	12.3	12.4	12.6	12.8
8	46.4	10.9	11.1	11.2	11.4	11.5	11.7	11.8	12.0	12.1	12.3	12.5
9	48.2	10.6	10.8	10.9	11.1	11.2	11.4	11.5	11.7	11.9	12.0	12.2
10	50.0	10.4	10.5	10.7	10.8	11.0	11.1	11.3	11.4	11.6	11.7	11.9
11	51.8	10.1	10.3	10.4	10.6	10.7	10.9	11.0	11.2	11.3	11.5	11.6
12	53.6	9.9	10.1	10.2	10.3	10.5	10.6	10.8	10.9	11.0	11.2	11.3
13	55.4	9.7	9.8	10.0	10.1	10.2	10.4	10.5	10.7	10.8	10.9	11.1
14	57.2	9.5	9.6	9.8	9.9	10.0	10.2	10.3	10.4	10.6	10.7	10.8
15	59.0	9.3	9.4	9.5	9.7	9.8	9.9	10.1	10.2	10.3	10.5	10.6
16	60.8	9.1	9.2	9.3	9.5	9.6	9.7	9.9	10.0	10.1	10.2	10.4
17	62.6	8.9	9.0	9.1	9.3	9.4	9.5	9.7	9.8	9.9	10.0	10.2
18	64.4	8.7	8.8	9.0	9.1	9.2	9.3	9.5	9.6	9.7	9.8	10.0
19	66.2	8.5	8.7	8.8	8.9	9.0	9.1	9.3	9.4	9.5	9.6	9.7
20	68.0	8.4	8.5	8.6	8.7	8.8	9.0	9.1	9.2	9.3	9.4	9.6
21	69.8	8.2	8.3	8.4	8.5	8.7	8.8	8.9	9.0	9.1	9.3	9.4
22	71.6	8.0	8.2	8.3	8.4	8.5	8.6	8.7	8.8	9.0	9.1	9.2
23	73.4	7.9	8.0	8.1	8.2	8.3	8.4	8.6	8.7	8.8	8.9	9.0
24	75.2	7.7	7.8	8.0	8.1	8.2	8.3	8.4	8.5	8.6	8.7	8.8
25	77.0	7.6	7.7	7.8	7.9	8.0	8.1	8.2	8.4	8.5	8.6	8.7
26	78.8	7.5	7.6	7.7	7.8	7.9	8.0	8.1	8.2	8.3	8.4	8.5
27	80.6	7.3	7.4	7.5	7.7	7.7	7.8	7.9	8.1	8.2	8.3	8.4
28	82.4	7.2	7.3	7.4	7.5	7.6	7.7	7.8	7.9	8.0	8.1	8.2
29	84.2	7.1	7.2	7.3	7.4	7.5	7.6	7.7	7.8	7.9	8.0	8.1
30	86.0	6.9	7.0	7.1	7.2	7.3	7.4	7.5	7.6	7.7	7.8	7.9
31	87.8	6.8	6.9	7.0	7.1	7.2	7.3	7.4	7.5	7.6	7.7	7.8
32	89.6	6.7	6.8	6.9	7.0	7.1	7.2	7.3	7.4	7.5	7.6	7.7
33	91.4	6.6	6.7	6.8	6.9	7.0	7.1	7.2	7.3	7.4	7.5	7.5
34	93.2	6.5	6.6	6.7	6.8	6.9	7.0	7.0	7.1	7.2	7.3	7.4
35	95.0	6.4	6.5	6.6	6.7	6.8	6.8	6.9	7.0	7.1	7.2	7.3
36	96.8	6.3	6.4	6.5	6.6	6.6	6.7	6.8	6.9	7.0	7.1	7.2
37	98.6	6.2	6.3	6.4	6.5	6.5	6.6	6.7	6.8	6.9	7.0	7.1
38	100.4	6.1	6.2	6.3	6.4	6.4	6.5	6.6	6.7	6.8	6.9	7.0
39	102.2	6.0	6.1	6.2	6.3	6.3	6.4	6.5	6.6	6.7	6.8	6.9
40	104.0	5.9	6.0	6.1	6.2	6.2	6.3	6.4	6.5	6.6	6.7	6.7

CALIBRATION TABLE - SALT WATER APPLICATIONS

Temp °C	°F	Salinity - parts per thousand				
		0	10	20	30	40
0	32.0	14.6	13.6	12.7	11.9	11.1
1	33.8	14.2	13.3	12.4	11.6	10.8
2	35.6	13.8	12.9	12.1	11.3	10.6
3	37.4	13.4	12.6	11.8	11.0	10.3
4	39.2	13.1	12.3	11.5	10.7	10.0
5	41.0	12.8	11.9	11.2	10.5	9.8
6	42.8	12.4	11.6	10.9	10.2	9.6
7	44.6	12.1	11.4	10.7	10.0	9.4
8	46.4	11.8	11.1	10.4	9.8	9.4
9	48.2	11.5	10.8	10.2	9.5	8.9
10	50.0	11.3	10.6	9.9	9.3	8.7
11	51.8	11.0	10.3	9.7	9.1	8.6
12	53.6	10.8	10.1	9.5	8.9	8.4
13	55.4	10.5	9.9	9.3	8.7	8.2
14	57.2	10.3	9.7	9.1	8.6	8.0
15	59.0	10.1	9.5	8.9	8.4	7.9
16	60.8	9.9	9.3	8.7	8.2	7.7
17	62.6	9.7	9.1	8.6	8.1	7.6
18	64.4	9.5	8.9	8.4	7.9	7.4
19	66.2	9.3	8.7	8.2	7.7	7.3
20	68.0	9.1	8.6	8.1	7.6	7.2
21	69.8	8.9	8.4	7.9	7.5	7.0
22	71.6	8.7	8.2	7.8	7.3	6.9
23	73.4	8.6	8.1	7.6	7.2	7.8
24	75.2	8.4	7.9	7.5	7.1	6.7
25	77.0	8.2	7.8	7.4	7.0	6.6
26	78.8	8.1	7.6	7.2	6.8	6.5
27	80.6	7.9	7.5	7.1	6.7	6.4
28	82.4	7.8	7.4	7.0	6.6	6.2
29	84.2	7.7	7.3	6.9	6.5	6.1
30	86.0	7.5	7.1	6.8	6.4	6.1
31	87.8	7.4	7.0	6.6	6.3	6.0
32	89.6	7.3	6.9	6.5	6.2	5.9
33	91.4	7.2	6.8	6.4	6.1	5.8
34	93.2	7.0	6.7	6.3	6.0	5.7
35	95.0	6.9	6.6	6.2	5.9	5.6
36	96.8	6.8	6.5	6.1	5.8	5.5
37	98.6	6.7	6.4	6.1	5.7	5.5
38	100.4	6.6	6.3	6.0	5.7	5.4
39	102.2	6.5	6.2	5.9	5.6	5.3
40	104.0	6.4	6.1	5.8	5.5	5.2

The table is referred to a barometric pressure of 760 mm Hg.

At other air pressures, the values should be corrected in the following way:

$$\text{Corrected value} = \text{Table value} \times \frac{\text{Actual pressure}}{760}$$

Example:

Temperature = 14°C

Salinity = 30 ppt

Air pressure = 742 mm Hg

$$\text{Corrected value} = 8.6 \times \frac{742}{760} = \underline{\underline{8.4}}$$